

## Contact us



Tel

0555-6767999



Fax

0555-6768401



E-mail

info@raymaxlaser.cc



BoWang Industrial Zone, Ma'anshan city, Anhui, China



## RAYMAX PRODUCT MANUAL



PROFESSIONAL SHEET  
METAL MACHINES PRODUCER

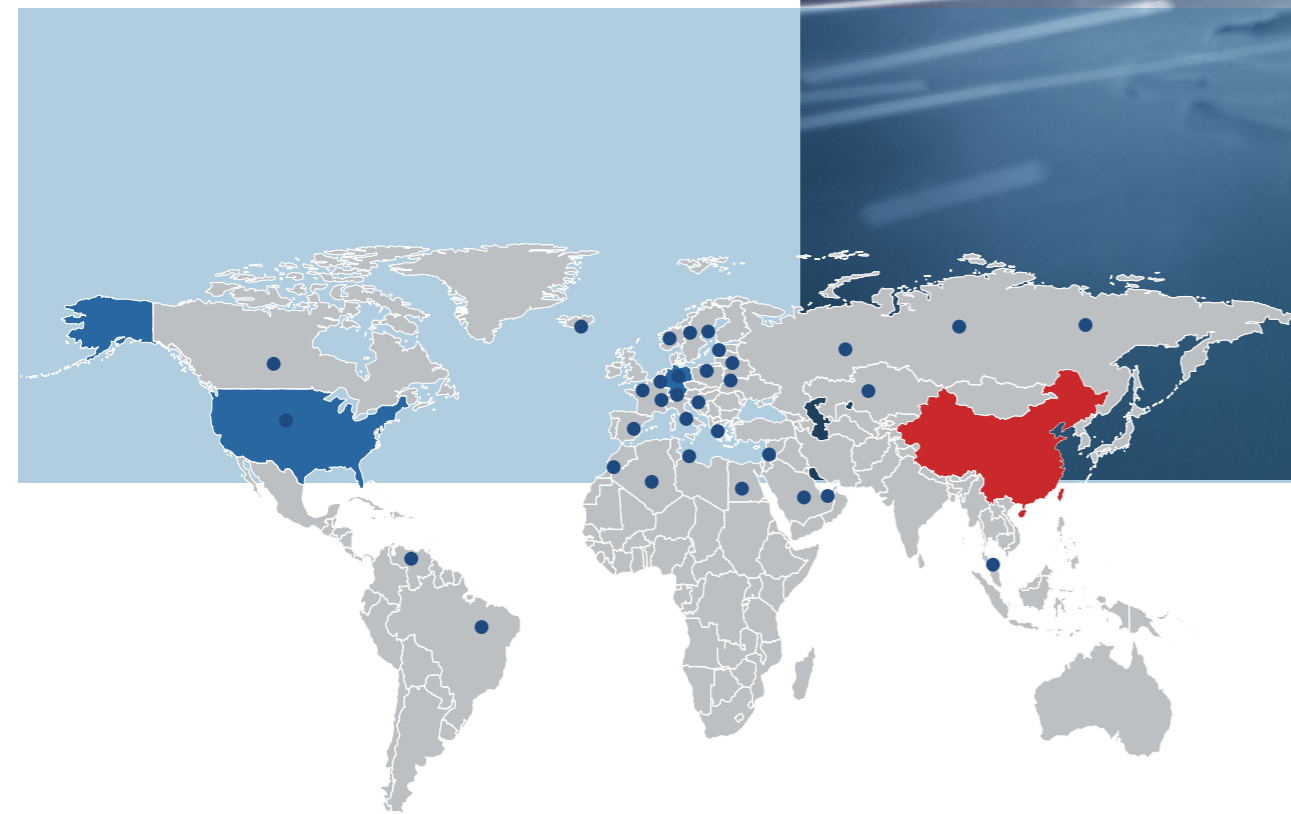

# HELLO!



ANHUI ZHONGRUI MACHINE MANUFACTURING CO., LTD WAS BUILT IN 2002 AND LOCATED IN BOWANG SPECIAL ECONOMIC ZONE, ANHUI PROVINCE, CHINA.

2002  
2023

## About Us the strength of the company

We are dedicated to the R&D and manufacturing of medium or high level processing equipment for

- Fiber laser cutting machine of metal plates
- CNC press brake bending machine
- Hydraulic shearing machine
- Hydraulic press
- Punching machine (power press)

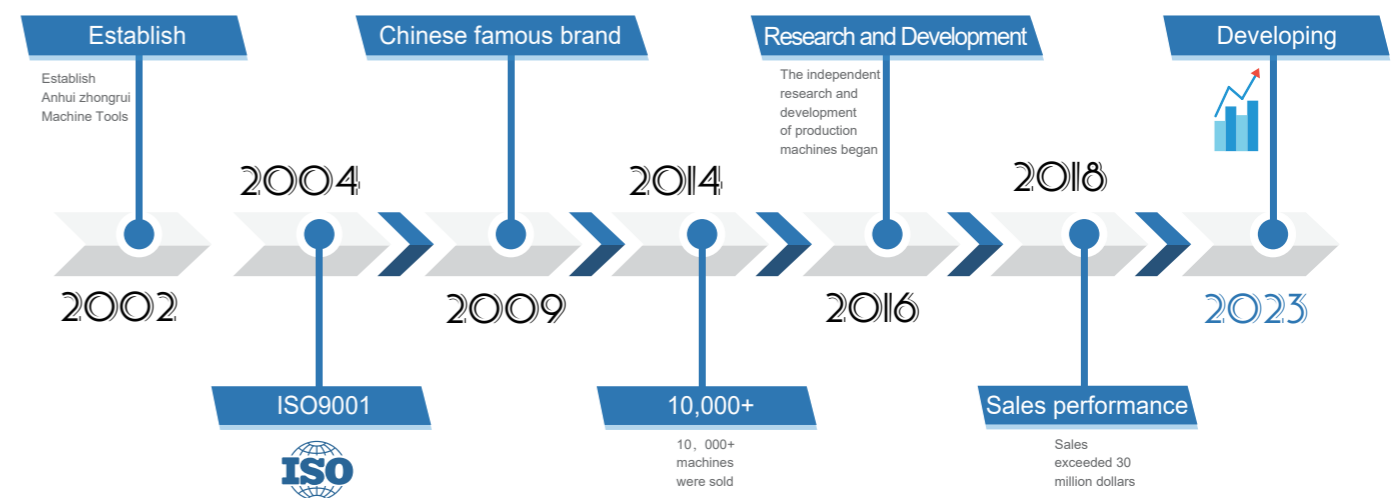

# WF67Y SERIES NC PRESS BRAKE MACHINE



- ESTUN E21 NC control System
- Plate Support Arms
- Germany Bosch-Rexroth Hydraulic
- Germany EMB Tubing connector
- Germany Siemens Main Motor
- Schneider Electric
- Hydraulic & Electrical overload protection
- Top and Bottom Tooling(86°, R0.6mm)
- Powered Depth Y-axis & Back gauge X-axis
- HIWIN Ball screws & Polished rod with 0.05 mm accuracy

The WF67Y Series NC Press Brake machine are optimal for the forming of parts with low operation cost. WF67Y Series NC Press Brake machine have Torsion bar synchronous NC two axes control capability just like our larger Press Brakes.

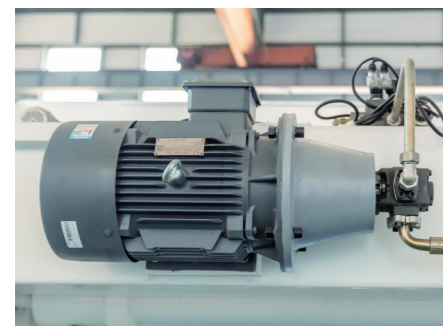

Main Motor Germany Siemens Brand

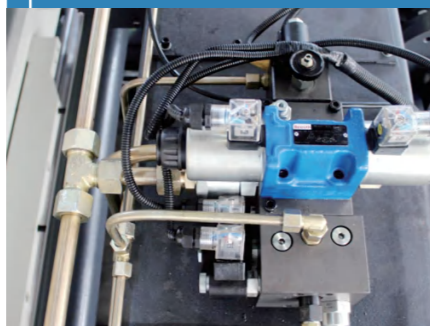

BOSCH-REXROTH Hydraulic System



Fast Clamping

## OPTIONAL EQUIPMENT



### E21

- X, Y-axis intelligent positioning program. Easy operation with cost performance



### E200

- X, Y-axis intelligent positioning program With ESTUN Servo Motor AND Driver



### CYBELEC CT 8P

- NC System With Inovance Servo Motor AND Driver 2D graphic CNC System



### DELEM DA41

- NC Controller with Inovance Servo Motor AND Driver Data programming with angle and mold parameter input

## SPECIFICATIONS:

Type	Bending Capacity KN	Bending Length mm	Between Columns mm	Throat Depth mm	Slide Stroke mm	Stroke Adjustment mm	Max. Shut Height mm	Oil Cylinder dia mm	Main Motor Power kw	Net Weight kg	Outline Size (L×W×H) mm
30X1600	300	1600	1300	200	80	60	210	90	3	1800	2000×1150×1780
40X1600	400	1600	1300	250	80	60	290	120	5.5	2000	2000×1250×1800
40X2500	400	2500	1700	250	80	60	290	120	5.5	2500	2680×1250×2000
50X2500	500	2500	1900	250	100	75	300	125	5.5	2800	2900×1250×2000
63X2500	630	2500	1900	320	120	75	300	130	5.5	3200	2900×1500×2200
63X3200	630	3200	2600	320	120	75	300	130	5.5	3700	3600×1500×2200
80X2500	800	2500	1900	320	150	75	300	150	7.5	3500	2900×1600×2270
80X3200	800	3200	2600	320	150	75	300	150	7.5	4000	3600×1600×2270
100X2500	1000	2500	1900	320	170	75	350	170	7.5	5500	2900×1700×2420
100X3200	1000	3200	2600	320	170	75	350	170	7.5	6000	3600×1700×2420
100X4000	1000	4000	3100	320	170	75	350	170	7.5	7000	4400×1700×2420
125X2500	1250	2500	1900	320	170	75	350	180	11	5600	2900×1750×2450
125X3200	1250	3200	2600	320	170	75	350	180	11	6300	3600×1750×2450
125X4000	1250	4000	3100	320	170	75	350	180	11	7300	4400×1750×2450
160X2500	1600	2500	1900	320	200	75	420	210	11	7700	2900×1800×2700
160X3200	1600	3200	2600	320	200	75	420	210	11	8900	3600×1800×2700
160X4000	1600	4000	3100	320	200	75	420	210	11	9800	4400×1800×2700
160X6000	1600	6000	5000	320	200	75	420	210	11	11500	6400×1900×2700
200X3200	2000	3200	2600	320	200	75	450	230	11	9700	3600×2000×2700
200X4000	2000	4000	3100	320	200	75	450	230	11	11500	4400×2000×2700
200X6000	2000	6000	5000	320	200	75	450	230	11	15500	6400×2100×2700
250X3200	2500	3200	2600	380	250	75	450	280	18.5	10500	3600×2150×3000
250X4000	2000	4000	3100	380	250	75	450	280	18.5	12500	4400×2150×3000
250X6000	2500	6000	5000	380	250	75	450	280	18.5	17500	6400×2200×3000
300X3200	3000	3200	2600	380	250	75	450	300	22	14500	3600×2300×3200
300X4000	3000	4000	3100	380	250	75	450	300	22	18500	4400×2300×3200

# WF67K SERIES CNC PRESS BRAKE MACHINE



CNC sheet metal press brake with streamlined design, high speed, high precision and high rigidity. Electro hydraulic servo system, full loop controlling the synchronization of the upper slider. Mechanical compensation on crowning of worktable and deformation compensation on throat, ensuring good bending strength and precision. Backgauge is driven by digital AC servo motor, moved with ball screw, guided by linear guide.

## PRODUCT ATTRIBUTE

- DELEM DA-58T CNC control unit with 2D graphics
- 4+1 axis
- X, R, Z1, Z2-Axis with HIWIN linear guide and Ball Screw
- Standard BGA-2 for X, R-axis ( X=600mm,R=200mm)
- CNC motorized wave crowning
- Large trio of value:
  - Large open height
  - Large stroke
  - Large throat depth
- Bosch-Rexroth hydraulic valve block, valves
- High efficiency Siemens motor
- Rear cover: Safety barriers (Category IV)
- Sheet metal frontal supports
- Front and rear lighting
- Offline software Delem Profile-TL
- Front Safety: AKAS LC-II F safety laser (Category IV) or DSP-AP safety

## PRODUCT DETAILS

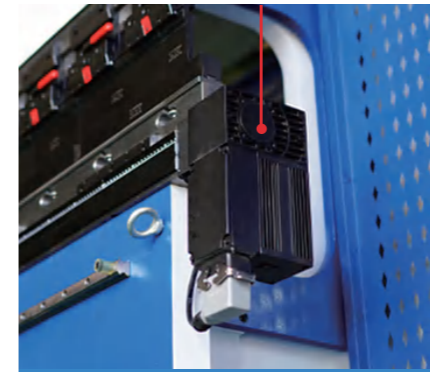

Crowning table



Hydraulic clamping



Hydraulic System

## SPECIFICATIONS:

Type	Bending Capacity KN	Bending Length mm	Between Columns mm	Throat Depth mm	Slide Stroke mm	back gauge stroke mm	Max. Shut Height mm	Oil Cylinder dia mm	Main Motor Power kw	Net Weight kg	Outline Size (L×W×H) mm
40T/1600	400	1600	1165	350	160	500	460	100	5.5	3370	2650×1650×2400
63T/2500	630	2500	1960	380	165	500	460	120	5.5	5000	3550×1700×2500
80T/2500	800	2500	1960	380	165	600	460	136	7.5	5100	3550×1700×2500
80T/3200	800	3200	2760	380	165	600	460	136	7.5	6500	4250×1700×2500
100T/3200	1000	3200	2750	390	200	600	490	151	7.5	7700	4300×1800×2650
125T/3200	1250	3200	2750	390	200	600	490	172	11	7800	4300×1800×2680
160T/3200	1600	3200	2740	400	200	600	490	197	15	9500	4400×1900×2720
200T/3200	2000	3200	2730	400	200	600	490	218	18.5	1600	4400×1900×2720
300T/3200	3000	3200	2720	500	200	600	580	270	22	1900	4400×2200×3500
100T/4000	1000	4000	3350	390	200	600	490	151	7.5	8800	5200×1800×2650
125T/4000	1250	4000	3350	390	200	600	490	172	11	9000	5200×1800×2680
160T/4000	1600	4000	3340	400	200	600	490	197	15	1600	5200×1900×2720
200T/4000	2000	4000	3330	400	200	600	490	218	18.5	1750	5200×1900×2800
250T/4000	2500	4000	3330	450	250	600	520	244	18.5	2000	5200×1900×2850
300T/4000	3000	4000	4920	500	300	600	580	270	22	2300	5200×1950×2900
200T/6000	2000	6000	4940	400	200	800	490	218	18.5	2600	7200×1900×2800
250T/6000	2500	6000	4930	450	250	800	520	244	18.5	3000	7200×1900×2850
300T/6000	3000	6000	4920	500	300	800	580	270	22	3200	7200×1950×2900
400T/6000	4000	6000	4920	500	300	800	580	325	37	3600	7200×2000×2950
500T/6000	5000	6000	4910	500	300	800	600	360	45	4500	7200×2050×3000

Delem

	DA-52S	DA-58T	DA-66T	DA-69T				
Axes	4	4	4	6	12	12	12	12
Screen	10"	10"	15"	15"	17"	15"	17"	19"
2D graphic view	—	●	●	●	●	●	●	●
3D graphic view	—	—	—	●	●	●	●	●
3D programming	—	—	—	—	—	○	●	○
Auto tooling selection	—	—	—	—	●	○	●	○
Touch screen	●	●	●	●	●	●	●	●
USB ports	1	2	1	2	2	4	2	4
2D DXF import	—	—	—	—	—	●	●	●
3D IGES/STEP import	—	—	—	—	—	—	●	○
3D Offline import	—	—	—	—	○	○	●	○
Export DXF 2D FP	—	—	—	—	—	○	●	○
Offline software	Profile TL	Kvara PC	Profile TL	Kvara PC	Profile TL	Kvara PC	Pe Profile T3D	EsaBend 3D-M



ESA S630      ESA S640      VIS-S860      VIS-S875

**RAYMAX PRO CNC CROWNING TABLE:**

This feature eliminates the need for time consuming shimming by creating an adjustable crown in the middle of the table. In this system, over under wedge system creates a stable crown on the center of the table. The CNC controlled system is automatically set based on programmed part information.

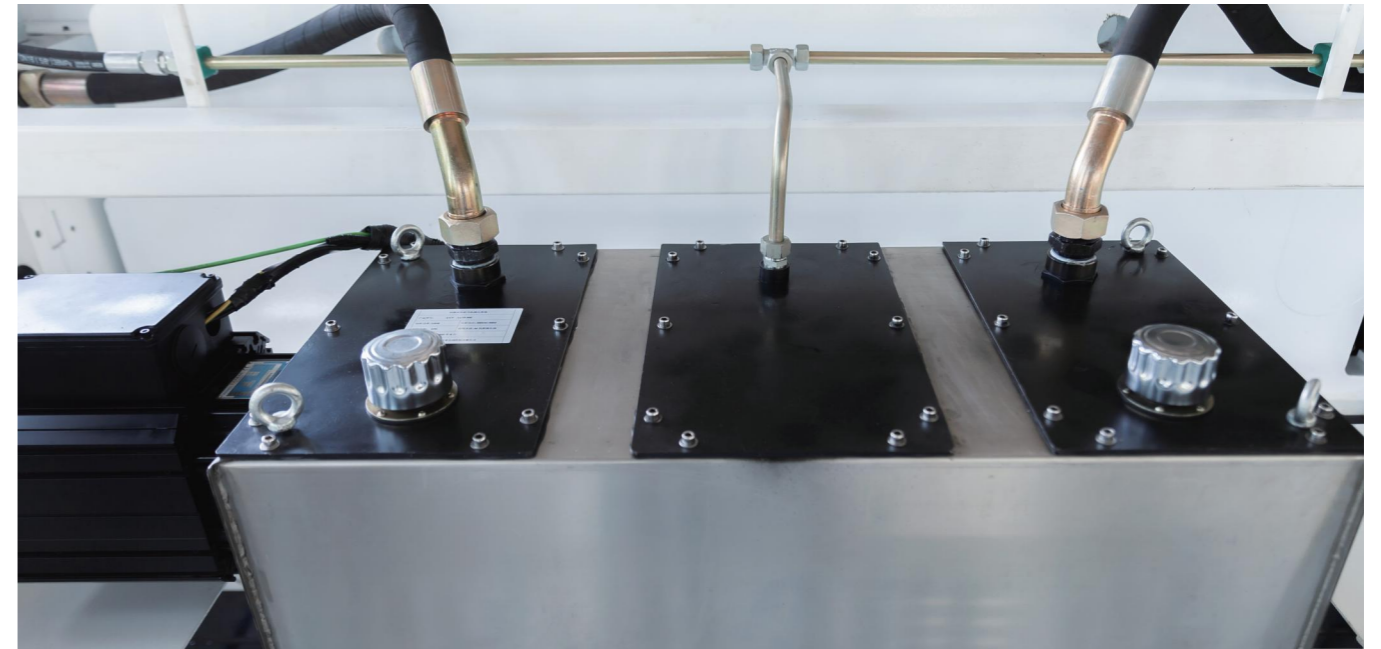
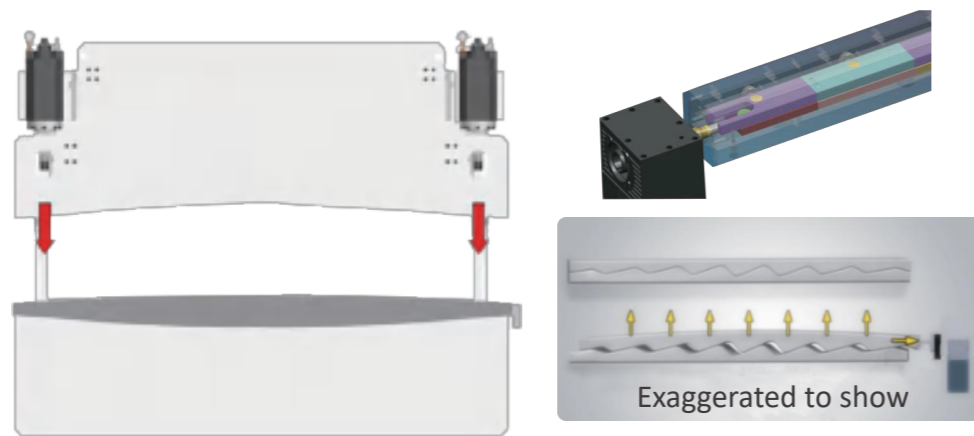

**RAYMAX® HYBRID SERVO FUNCTION**

A package of innovative and customer-oriented solutions aimed at reducing machine consumptions. RAYMAX® promotes a friendly environmental policy so that all our equipment features the Hybrid Eco Function.

- This hybrid servo-drive system improves the accuracy at target position.
- Depending on cycle characteristics and rating, servo pump drives achieve energy savings.

- Maximum stamina!**  
↑ Ultra-long service life
- Reduce cooling time!**  
Quality ↑ Higher Operation Speed ↑
- Faster & more efficient!**  
Speed ↑ more than 40% Oil Saving ↑
- Much faster!**  
Save time and costs ... ↑

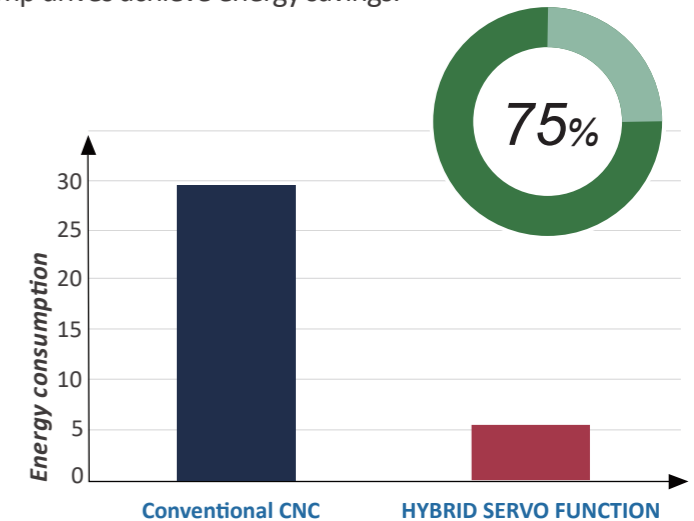

**CUSTOMER BENEFITS:**

- High dynamic for a higher productivity of the machine.
- Compliance with EU Directives.
- Lower energy for a green machine.
- Lower sound pressure level at 50 dB.
- The servo-motor, with closed loop speed control.
- Energy efficiency is up to 35 % compared to conventional systems.
- Due to low energy consumption, it gives advantages to the user with high efficiency & low operation cost.

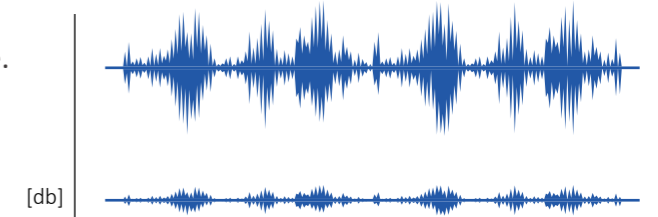

# WF67K SERIES CNC HYBRID PLUS PRESS BRAKE MACHINE



By adopting integrated control system, the hydraulic system ensures the working stability of machine tools and makes the appearance scientific and beautiful, which reduces the installation of pipelines and eliminates oil leakage.

## PRODUCT CONFIGURATION

### ESA VIS 875 CNC control unit with 3D graphics

- Y1, Y2 precision ram positioning
- Front Safety: AKAS LC-II F safety laser (Category IV) or DSP-AP safety
- BOSCH-REXROTH hydraulic valve block and valves
- INOVANCE efficiency servo motor
- Stand-by function for energy-saving drive
- Rear cover: Safety barriers (Category IV)
- Offline software Delem Kavra Easybend 3D
- ITALY DSP-AP LaserSafe & Front Safety Barrier with Monitoring Valve

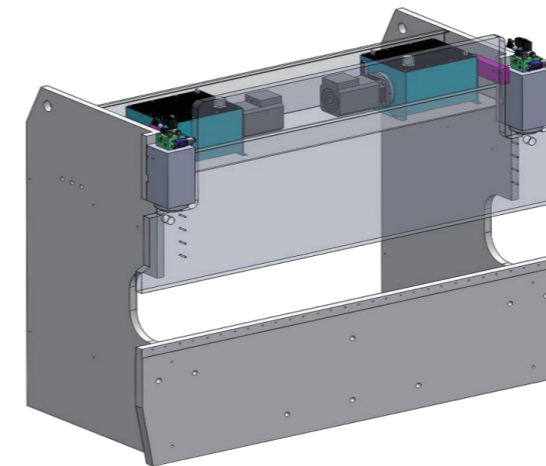
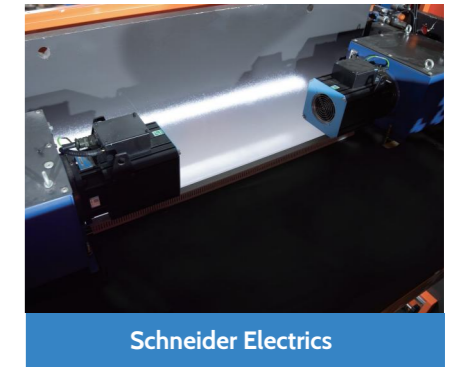
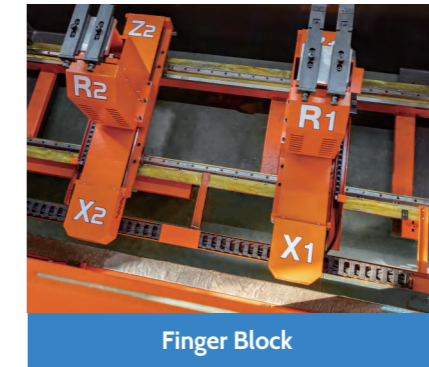

## HYBRID PLUS ADVANTAGES

- Saving: 60% electricity savings compared to conventional drives.
- Efficient: High up to 30%, more efficient (reduced cycle time).
- Accurate: More accurate positioning, up to 5um
- Quiet: Quieter of machine operation due to reduced noise
- Less: Hydraulic oil use is minimal, only 30% compared to conventional ones
- Easy: Easier to build, easier to maintain and lower failure rate of the machine.

### Maximum stamina!

↑ Ultra-long service life



### Reduced cooling time!

Quality ↑ Higher Operation Speed ↑



### Faster & more efficient!

Speed ↑ more than 40% Oil Saving ↑



### More faster!

Save time and costs ... ↑

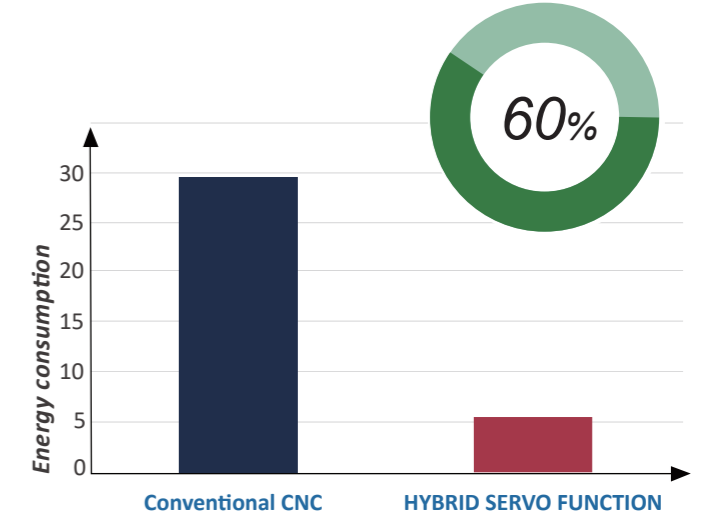

## SYSTEM FEATURES

- Minimize the overflow loss.
- Infinitely adjustable speed can be realized. Adjustment range can from 0 to maximum. Precise demand oil quantity dispensing is optimized by the speed of dynamic servo motor.
- Compared with two-way pump servo control and ordinary directional valve control, double servo pump control has smoother operation, easy and convenient installation, beautiful appearance, reliable performance, simple control and low failure rate.
- No idle power, servo motor can be turned off when no flow or pressure is needed.
- Compact design, tank assembly and cylinder are connected together by transition block, no piping connection.
- Further improves cleanliness. Makes machine building easier.

### BGA-4 CNC BACK GAUGE SYSTEM

RAYMAX® press brake are provided and equipped with BGA-4 CNC backgauge constituted by a solid structure in order to assure the best accuracy and high precision in axes positioning.

RAYMAX® BGA-4 for CNC BackGauge:

- Stroke X = 1000 mm
- Max. Speed X = 450 mm/s
- Stroke R = 250 mm
- Max. Speed Z = 550 mm/s

Advantages:

- X ,R-Axis with HIWIN linear guide and Ball Screw.
- CNC(Manual) Z1,Z2-axis with HIWIN linear guide.
- Unprecedented positioning accuracy of ±0.05 (optional ±0.01).
- To reach maximum versatility you can automate both backstops with X1-X2 axes, reaching an angle of 80° on oblique bends.

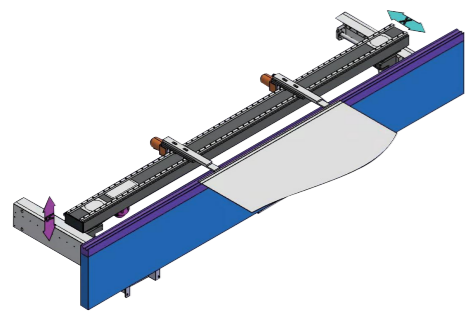

### BGA-6 CNC BACK GAUGE SYSTEM

RAYMAX® press brake are provided and equipped with BGA-6 CNC backgauge constituted by a solid structure in order to assure the best accuracy and high precision in axes positioning.

RAYMAX® BGA-6 for CNC BackGauge:

- Stroke X = 800 mm
- Max.Speed X = 450 mm/s
- Stroke R = 250 mm
- Speed Z = 550 mm/s

Advantages:

- Fast, highly accurate safe movement
- Resistance to crash.
- Maintenance free.
- Adjustment availability at every point.

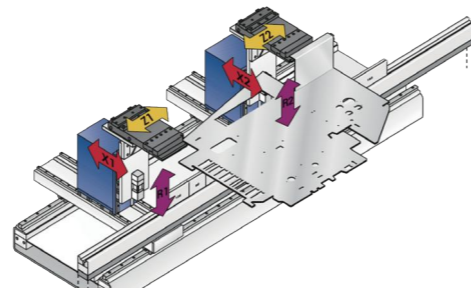

### CNC FRONT FOLLOWER SUPPORTS



- Equipped with a parking, it minimizes the effects of reverse bending.
- Equipped with a brush table to prevent any sheet from being scratched, slipped or dropped.
- It suits for all kinds of large sheet metal, especially thin and large plates, which lightens the operator's work moving heavy pieces, improves bending efficiency and reduces risk for operators.
- Communicating with the control system, it perfectly maintains 100% synchronization with the Y-axis during the bending process.
- Bend as close as 70°
- Load capacity 180kg/380kg each one

### WILA® CLAMPING SYSTEM FOR OPTION

#### New Standard Pro Top Clamping

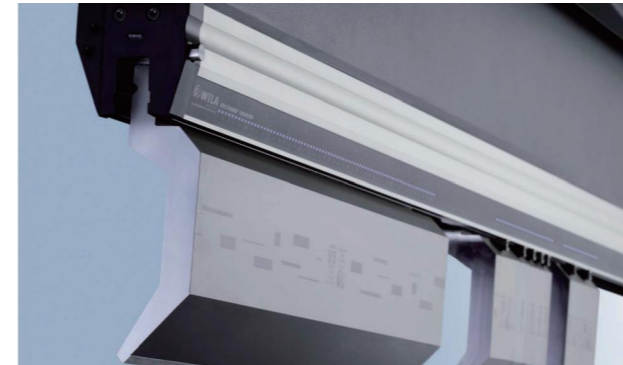

The Wila's New Standard' Tooling System has become the market leader for precision, quality and flexibility for RAYMAX press brake. WILA's state-of-the-art clamp systems offer options for the ultimate efficiently changing tools with Smart Tool Locator (STL)\*, which has made process easier and safer.

#### New Standard Pro Tool Holders



The lower fixture of WILA is integrated with the workbench and adopts CRM 7. It is a CNC-driven motor, which has been designed for New Standard Pro Crowning. This motor makes it possible to horizontally insert and remove bottom tools from both ends. The CRM 7 motor is available for crowning lengths up to 4300 mm.

### ROLLERI PNEUMATIC CLAMPING FOR OPTIONAL



The new patented system enables manual pneumatic or hydraulic vertical clamping of your top tools. The special features are the enormously simple handling and the surprisingly low price, which guarantees huge efficiency.

- fast vertical tool change for all Rolleri R1 type punches
- can be used without modifying Rolleri R1 type punches
- safe and fast tool change
- substantial improvement in time consumption and related costs
- secure against tool falling down
- available in manual, pneumatic and hydraulic models
- mounting: Simply from the bottom into the housing, tighten - DONE!
- disassembly: Untighten, gently lift tool and remove it downwards



### ANGLE MEASUREMENT LASER CHECK10-12(OPTIONAL)



Instead, a complete system is connected to the press brake, which includes connection ports for different press brake controllers, strain gauges to measure spring back and a drive system for sensor movement. If the controller can run lasercheck software, the separation of sensor and CPU can provide a cost-effective solution.

- Angle measurement
- Spring back measurement
- Very high accuracy
- Works contactless

# QC12Y SERIES HYDRAULIC SWING BEAM SHEARING MACHINE

The hydraulic swing beam shear is the perfect solution for cutting sheet metal with thickness between 4mm and 20mm. The hydraulic swing beam shear can handle the large dimensions required in tube and roll forming manufacturing lines. Besides handling large dimensions, the hydraulic swing beam shear can also be configured for piercing and blanking. Here at RAYMAX, we guarantee that we can provide you with the hydraulic shear that will get the job done.



## PRODUCT DETAILS



Siemens Motor



Bosch Rexroth Hydraulic System



Blade Clearance Adjustment



Pressing Mechanism



• ESTUN 21S

Intelligent and unilateral positioning  
 Work-piece counting function  
 Double programmable digital output  
 40 programs stored, 25 steps per program  
 One key back-up/restore of parameters  
 Unit for mm/inch.



### FRONT FEEDING TABLE

Feeding the metal sheet automatically controlled by CNC Controller with high precision and efficiency.



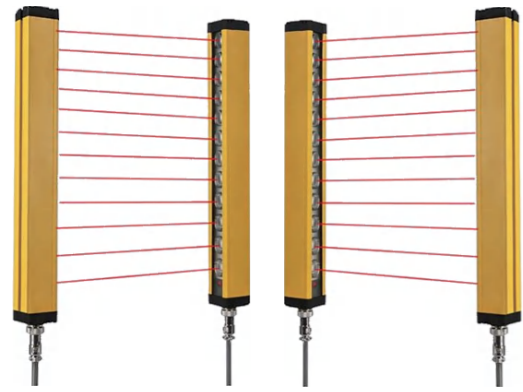

**LIGHT CURTAIN**  
Protect operator  
from dangerous  
operation

**SPECIFICATIONS**

Type	thickness of plating mm	Shear Angle (°)	Between Columns mm	Throat Depth mm	number of strokes (min-1)	Blade length mm	Bench height mm	Oil pump ml/r	Main Motor Power kw	Net Weight kg	Outline Size (L×W×H) mm
4X2500	4	1.5	2720	100	18	2600	750	25	7.5	3100	2900x1500x1580
4X3200	4	1.5	3420	100	14	3300	750	25	7.5	5200	3580x1500x1580
4X4000	4	1.5	4220	100	12	4100	750	25	7.5	6700	4480x1500x1580
6X2500	6	1.5	2720	125	18	2600	810	25	7.5	4600	2990x1650x1620
6X3200	6	1.5	3420	125	14	3300	810	25	7.5	5900	3690x1650x1620
6X4000	6	1.5	4220	125	12	4100	810	25	7.5	7700	4480x1850x1700
6X6000	6	1.5	6220	125	12	6100	850	32	11	15000	6480x2000x2000
8X2500	8	1.5	2720	125	18	2600	810	25	11	5000	2990x1700x1700
8X3200	8	1.5	3420	125	14	3300	810	25	11	6000	3690x1700x1700
8X4000	8	1.5	4220	125	12	4100	810	25	11	8000	4480x1850x1700
8X6000	8	1.5	6220	125	12	6100	850	32	15	17000	6480x2000x2000
10X2500	10	2	2720	125	14	2600	850	32	15	8300	2990x1700x1700
10X3200	10	2	3420	125	14	3300	850	32	15	10200	3690x1700x1700
10X4000	10	2	4220	125	12	4100	850	40	18.5	11500	4480x1850x1750
10X6000	10	2	6220	125	4	6100	850	40	18.5	19000	6450x2450x2350
12X2500	12	2	2720	125	7	2600	850	63	18.5	9300	3050x2100x2000
12X3200	12	2	3420	125	7	3300	850	63	18.5	11200	3495x2100x2000
12X4000	12	2	4220	125	6	4100	850	63	18.5	11000	4450x2150x2000
12X6000	12	2.3	6220	125	4	6100	900	63	18.5	23000	6450x2350x2650
16X2500	16	2.3	2720	125	8	2600	850	63	18.5	10400	3145x2127x2135
16X3200	16	2.3	3420	125	7	3300	850	63	18.5	12000	3600x2127x2135
16X4000	16	2.3	4220	125	6	4100	850	63	18.5	15500	4350x2200x2150
16X6000	16	3	6220	125	3~4	6100	900	80	30	27000	6350x2400x2750
20X3200	20	3	3420	120	3~4	3300	870	80	30	15300	4080x2450x2500
20X4000	20	3	4220	120	3~4	4100	870	80	30	18500	4350x2450x2500
20X6000	20	3	6220	120	3~4	6100	920	80	37	30000	6350x2500x2900

**QC11Y SERIES HYDRAULIC GUILLOTINE SHEARING MACHINE**

**FEATURE**

The QC11Y series is the top of the line, incorporating all the latest technology to offer the highest level of functionality. With our hydraulic angle setting and user friendly control panel, you will be able to easily cut different material thickness. QC11Y shears could provide speed, precision, accuracy and repeatability.

- ELGO P40T CNC control System.
- Servo motor controlled back gauge .
- Blade gap adjustment, cutting Angle & Back gauge by P40T CNC System.
- HIWIN Ball screws & Polished rod with 0.01 mm accuracy.
- Squaring Arm and Front Support Arms .
- Germany Bosch-Rexroth Hydraulic .

- Germany EMB Tubing connector.
- Germany Siemens Main Motor.
- Schneider Electric .
- Hydraulic & Electrical overload protection .
- Cutting Line Illumination and wire for shadow line cutting.
- Top blade with two cutting edges and bottom. blade with four cutting edges. (6CrW2Si).

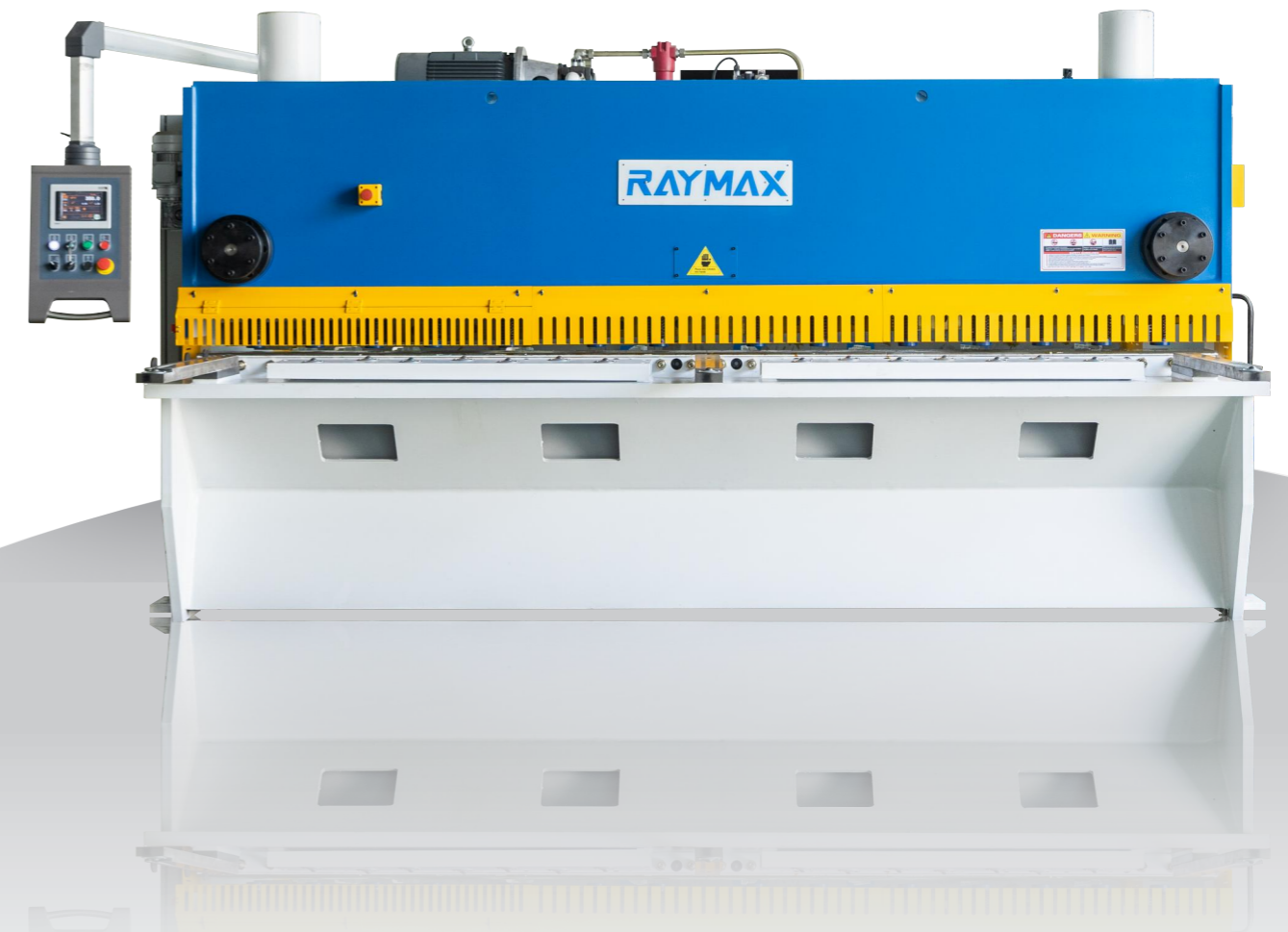

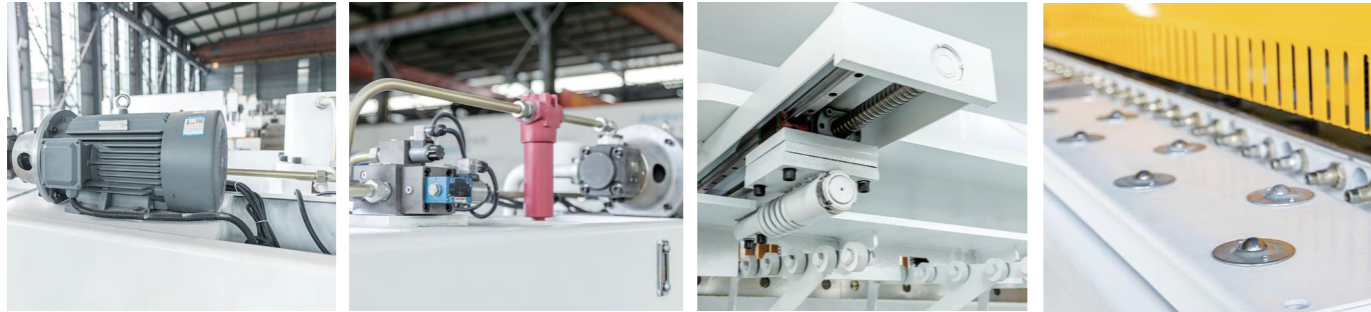

Siemens motor

Bosch Rexroth Hydraulic System

HIWIN ball screw & linear guide

Workbench



**Pneumatic back supporter**

Rear pneumatic support system provides support and allows more precise cuts by keeping the material lifted throughout the cut, avoiding hanging down the wide and thin sheets.

**OPTIONAL EQUIPMENT**

standard



**ELGO P40T**

- GERMANY ELGO P40T NC Control Unit:  
Large Color 7" LCD Touch Screen  
Back / front gauge control  
Auto Setting of Blade Clearance  
Auto Setting of Rake Angle  
Stroke length limitation  
Manual movement of all axes



**DELEM DAC - 360T**

- Panel based housing  
Bright LCD screen  
Back / front gauge control  
Retract function  
Cutting angle and gap control  
Stroke length limitation  
Manual movement of all axes



**CYBELEC CT 8**

- 7" monochrome LCD Touch screen  
RF-link wireless radio frequency data communication allow backup and restoring operations  
On-line help and interactive warning pop-ups  
Angle and back gauge correction.



**SPECIFICATIONS**

Type	Cut Thickness mm	Cut length mm	Shear Angle Degree	SPM min-1	Back Gauge mm	Throat Depth mm	Main Motor kw	Net Weight kg	Outline Size (L×W×H) mm
4×2500	4	2500	1°30'	≥22	600	100	5.5	4650	3300×1600×1700
4×3200	4	3200	1°30'	≥18	600	100	7.5	4950	3950×1600×1700
4×4000	4	4000	1°30'	≥12	600	100	7.5	6900	4600×1705×1600
6×2500	6	2500	1°30'	≥16	600	120	7.5	5140	3150×1500×1600
6×3200	6	3200	1°30'	≥12	600	120	7.5	6250	4000×1700×1800
6×4000	6	4000	1°30'	≥10	600	120	7.5	8520	4650×1700×1800
6×6000	6	6000	1°30'	≥7	600	120	11	17000	6780×2450×2100
8×2500	8	2500	1°30'	≥14	600	120	7.5	5900	3180×1680×1700
8×3200	8	4000	1°30'	≥12	600	120	7.5	6500	4000×1800×1850
8×4000	8	3200	1°30'	≥10	600	120	11	7360	4680×1800×1850
10×3200	10	3200	1°50'	≥12	600	120	11	8100	4000×1950×1900
10×4000	10	6000	1°50'	≥6	600	120	18.5	21800	6880×2260×2100
12×2500	12	2500	2°	≥10	800	170	18.5	9600	3300×2030×1840
12×3200	12	3200	2°	≥9	800	170	18.5	11700	4200×2050×2100
12×4000	12	4000	1°80'	≥8	800	170	18.5	13800	4800×2270×2000
12×6000	8	6000	2°	≥4	800	320	30	38000	6900×2800×2500
16×2500	16	2500	2°9'	≥9	800	315	18.5	11100	3310×2240×2000
16×3200	16	3200	2°	≥8	800	320	18.5	12900	4200×2150×2200
16×4000	16	4000	2°	≥7	20-1000	320	18.5	19700	4820×2490×2460
16×6000	16	6000	2°	≥4	20-1000	320	22	44000	7100×2900×2650
20×3200	20	3200	2°30'	≥5	1000	320	30	22000	4190×2400×2300
20×6000	20	6000	2°30'	≥4	1000	150	55	51000	7100×3500×3050
25×2500	25	2500	3°	≥5	1000	325	37	20000	3450×2650×2800
25×3200	25	3200	3°	≥5	1000	325	37	27000	4130×3100×2800
32×2500	32	2500	3°30'	≥4	1000	350	45	32500	3550×3100×2800
32×3200	32	3200	3°30'	≥4	1000	350	45	42100	4335×3300×3280

## OPEN-TYPE DOUBLE-DRIVE FIBER LASER CUTTING MACHINE RX-D SERIES



### STANDARD EQUIPMENT

User friendly Cypcut Windows CAD/CAM CNC control unit.

Unique features:

- Very easy to operate.
- Quick and easy installation.
- Low investment and operating costs.
- The most cost-efficient solution for every requirement
- Flexible beam path
- High output power
- High optical quality
- Up to 300% faster cutting
- High wall plug efficiency (>30%)
- Copper, brass cutting ability
- High performance and high accuracy rack and pinion system.

### OPTIONAL EQUIPMENT

- HYPCUT Touch FSCUT8000 TwinCAT CNC System
- Shuttle Table and Clean Room
- Table size 2000x4000mm
- Pipe cutting system(220mm / 3000mm)
- Cutting Head from PRECITEC- Manual(500w-1500w)
- USA.IPG
- Raycus Fiber Laser Power(500w-2kw)

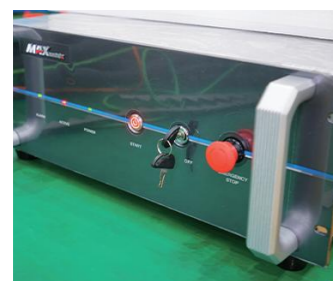

Laser Source



Laser Cutting Head



Transmission System



Control Cabinet

## ENCLOSED EXCHANGE TABLE FIBER LASER CUTTING MACHINE RX-H SERIES



### STANDARD EQUIPMENT

- CypCut Fscut 2000 CNC System
- Reliable laser fiber source from 1 to 6 kw
- Japan Shimpo racks & pinions
- Modern body made of composite material
- Traverse made of steel
- Pallet changer without hydraulics
- Raytools Auto Cutting Head
- Interlock closing system
- Class 1 laser safety windows
- Compact dust extractor

### OPTIONAL EQUIPMENT

- HYPCUT Touch FSCUT8000 TwinCAT CNC System
- BECKHOFF TwinCAT Touch Screen Control System
- Graphite Anti-burn Technology.
- Automatic nozzle cleaning 1.0
- Precitec Cutting head (Auto Focus)
- Pneumatic Pipe & Profile Cutting System
- Automatic loading / Unloading system SMART-LIFTER

### JAPAN'S FUJI OR YASKAWA SERVO DRIVER

Bear 3 times rated torque load, high speed good performance, strong overload protection



**Technical parameters**

Product Model	RX-3015	RX-6015	RX-4020	RX-6015
Working Area	3000*1500mm	6000*1500mm	4000*2000mm	6000*2000mm
Laser Power	1000W、1500W、2000W、3000W、4000W			
Positioning Accuracy	±0.03mm/m			
Repeated Positioning Accuracy	±0.02mm			
Maximum Moving Speed	120m/min			
Maximum Cutting Speed	60m/min			
Drive System	High precision gear and rack +high precision linear guide rail			
Voltage	380V AC±10%/50Hz			

**FSCUT Series 1000-8000 CNC Control System :**

- System upgrade is easy.
- System function can be extended by software itself, not like common CNC system, which must depend on the developers.
- Cypcut control uses hard disk storage process, coming huge amounts of NC memory.(more than 10 GB)
- With the professional automatic typesetting software, the cutting plate availability has increased 1%-5%,cutting productivity 10%-30%,significantly improving the cut quality ,process data management, data collection and statistics and other data management functions, visualization integrated interface, simple operation, easy to learn



**Self-centering chuck**

Automatic electric chuck, claw DC motor drive, clamping motor current is sensitive, adjustable and stable;  
Self-centering electric chuck, gear transmission mode, higher transmission efficiency, long working life and high work reliability.Locator® (STL)\* have made the changeover process easier and safer.



**CUTTING HEAD PRECITEC RAYTOOLS AG AUTO FOCUS**

The RAYTOOLS AG comes with the external motor and the built-in drive unit through the linear driver and the focusing lens can automatically change the position in the range of 25mm. The user can set the focus continuously through the program to complete the rapid piercing of thick sheets or other different thickness and material sheets.

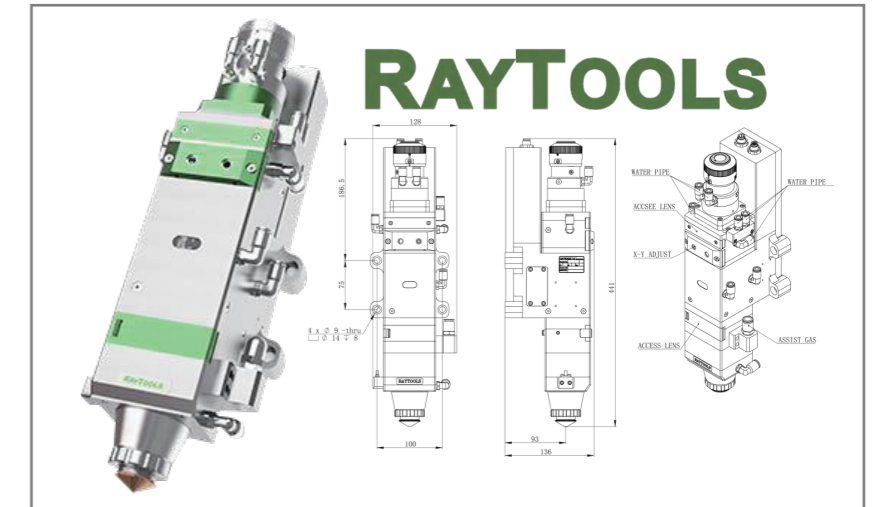

**BLT831—HIGH POWER LASER CUTTING HEAD**

**INTRODUCTION**

BLT high power is designed and adopts EtherCAT bus technology. BLT831 is a full function laser head mounted with all-round sensors, which is the most leading edge product on the market.

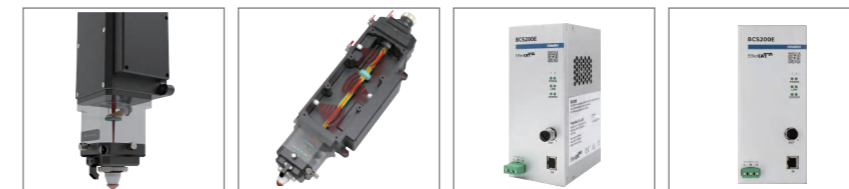

**PIERCETEC NEW PROCUTTER 2.0**

The ProCutter 2.0 APP is used to visualize the state of the laser cutting head and the query of error messages.



- Motorized focus position adjustment for automatic machine setup and piercing work.
- Lightweight and slim design created for fast acceleration and cutting speed.
- Drift-free, fast-reacting distance measurement.
- Permanent protective window monitoring.
- Automated piercing with PierceTec.
- Water cooling of the sheet metal with CoolTec.
- Completely dustproof beam path with protective windows.
- LED operating status display.
- Output of all sensor data via WLAN to APP and machine control possible.
- Pressure monitoring in the nozzle area (gas cutting) and in the head.

- Maximum stamina!  
Ultra-long service life.
- Easy parameter finding  
Quality Process window.

- Faster & more efficient!  
Speed Gas efficiency.
- Faster laser speed!  
Save time and costs.



### FIBER LASER RESONATOR IPG

•The fiber laser resonator is a separate unit unattached to the cutting machine; this facilitates the design of laser cutters to deal with high speed cutting of thin materials and high quality cutting of thick materials. The unit contains the high stability resonator, kinetically suspended. The laser resonator includes a communication system featuring the control unit and a closed cooling circuit.

Features of the IPG equipment are as follows:

- Direct control of all the fiber laser functions
- Synchronized control of the laser source
- Overall power control
- High speed perforation
- Edge machining function
- Cutting data library
- High speed fiber laser cutting
- Wall-plug Efficiency >40%
- Cost-effective Cutting System
- Maintenance-free Operation
- Fiber Delivery 50, 100, 150 or 200 μm
- CW Output Power up to 20 kW @ Workpiece
- New fiber block design with 3x increase in damage power threshold, resulting in increased reliability



MAX from CHINA



RAYCUS from CHINA



IPG from USA

### CUTTING SAMPLES



### LOADER & UNLOADER BRG SYSTEM 2.0

RAYMAX Loader & unloader BRG System 2.0 is the automated solution that best optimizes the flow of material, which improves both the safety at work and the safety of the process. The solutions included range from simple operation to fully automated operation.

Fast processing of the order, since the automatic loading and unloading reduces the preparation times, Considerably great use of machinery with only a slight increase in investment. Access to the production of parts with little manual work.

Automatic loading / Unloading system SMART-LIFTER.



### DUST REMOVAL SYSTEM

The workbench is connected by an industrial dust collector, which is flexible and convenient. It collects dust on the spot and handles it on the spot. It uses a high-power turbo fan with strong suction, which can effectively ensure the cleanliness of the air and ensure a clean and tidy production environment. With sound-absorbing material inside, the noise reduction effect is obvious, so there is no need to worry about noise interference.



# RX-TM SERIES PROFESSIONAL LASER PIPE CUTTING MACHINE



Intelligent pipe cutting system



High-quality cutting head



Precision helical rack



All automatic pneumatic chuck open clamp, white centering.

- Self-centering pneumatic chuck limit protection for thin pipe and will ensure clamping properly.
- Strong dynamic performance, helps to increase production efficiency.
- High speed fully automatic laser tube cutting machine, which can cut round pipes, rectangle tubes and shaped tubes.

## Automatic laser pipe cutting machine

Expert grade ultrahigh speed automatic laser pipe cutting machine, with strong cutting ability, ultra-high stability, high-quality processing, automatic feeding system, extremely low operating cost and ultra-high adaptability. It is the model of metal pipe processing industry.



### Technical Parameters:

Laser power		1000W-6000W
Maximum pipe length		12000mm
Maximum single pipe weight		25Kg/m
X axis	Positioning accuracy	0.05mm
	Positioning speed	120m/min
	Repeatability accuracy	0.05mm
Y axis	Positioning accuracy	0.05mm
	Positioning speed	80m/min
	Repeatability accuracy	0.03mm
Z axis	Positioning speed	60m/min

# HANDHELD LASER WELDING MACHINES RX-HW SERIES



## INTRODUCTION OF MAIN COMPONENTS

Compared with traditional arc welding, RX-HW-1000 enjoy following advantages: user-friendly design, technology upgrade and simple operation. Operators do not need skilled technical certificate to achieve exquisite welding. There is no need for secondary grinding after welding, which greatly reduces the professional limitations of the operator and the cost of manpower.



### Technical Parameters:

COMPARATIVE	MODEL	RX-HW-1000w	RX-HW-1500w
OPTICAL PROPERTIES	Rated Output Power (w)	>1000	>1500
	Operating Mode	Continuous/modulation	
	Polarization direction	Random	
	Output Power Adjustment Range (%)	10~100	
	Center Wavelength (nm)	1080+3	
	Output Power Instability	<3%	
	Maximum Modulation Frequency (kHz)	50	
	Indicates Red Light Power (mW)	>0.5	
	Output Interface	QBH	
	Output Fiber Core Diameter (um)	20	30/100
Output Fiber Length (m)	15		
ELECTRICAL PROPERTIES	Operating Voltage	220v + 10% - 50/60Hz	
	Maximum Power Consumption (w)	<5000	<6000
	Control Method	RS232/AD	
OTHER PROPERTIES	Size(WxHxD)	483 X 191 740	
	Weight (kg)	<60	
	Operating Temperature Range (°C)	5~40	
	Operating Humidity Range (%)	<70	
	Type Of Cooling	Water cooling	
	Cooling Water Temperature (°C)	Indoor	
	Cooling Water Temperature (°C)	25	
	Cooling Water Flow (L/min)	>12	>12
Storage Temperature (°C)	-10~60		

# Y27 SERIES HYDRAULIC PRESS MACHINE

Y27 Series C-type Hydraulic Press is a kind of multifunctional machine which has strong generality. It is suitable for the press fitting of shaft components and axle sleeve parts as well as the movements of coining and overprinting. It can also be used to press powder and plastic products which the requirements are not strict. At the same time, it mainly applies to the fields of machine tool, engineering machinery, electrical components, bearings, washing machine, automobile parts and motor components. It can even be used as assembly line. The pressure, stroke, and time of pressure maintaining can be regulated.



### Main features:

- \* Single Column with little space
- \* Foot Pedal Control
- \* Two hands start, easy to operate
- \* Whole Body Frame Processing
- \* Schneider/Siemens Electrics

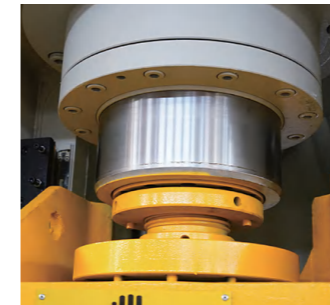

Hydraulic Cylinder



Control system



Schneider/Siemens Electrics



Workbench

### Applicable fields

This series of hydraulic presses are suitable for various stamping processes such as secondary stretch forming, bending, forming, blanking, and flanging of thin metal sheets, to meet the pressing of multi-planar complex structures, and are especially suitable for the following fields:

### Y27 Series type Hydraulic Press Product Features

The machine adopts a handle-pedal linkage system and is easy to operate. The hydraulic system uses integrated value block with the characteristic of compact structure and sensitive action. The machine also bears the features of low energy consumption and low noise.

### Y27 Series type Hydraulic Press Product Application

The type of machine is used for straightening and pressing spindle and other similar type of components. It can also be used for stretching simple shapes of parts or forming and blanking from sheets.

Machine tool type	25T	40T	63T	80T	100T	125T	160T	200T	250T	315T
Nomal force(KN)	250	400	630	800	1000	1250	1600	2000	2500	3150
Stroke adjustment(mm)	10-150	10-150	10-150	10-150	10-150	10-150	10-180	10-180	10-200	10-200
Maximum stroke of slider(mm)	150	150	150	150	150	150	180	180	200	200
Maximum mounting height(KN)	80-210	80-230	80-280	80-280	80-340	80-340	80-380	80-380	80-400	80-400
Stroke times(min)	10-50	10-40	10-40	10-40	10-40	10-40	10-30	10-30	10-30	10-30
Maximum pressure(mpa)	25	25	25	25	25	25	25	25	25	25
Fast down speed(m/s)	225	230	220	220	210	210	210	210	200	180
Working speed	10	10	8	8	8	8	8	8	6	6
Return speed	180	180	180	160	160	150	150	140	130	130
Workbench	L-R(mm)	500	590	650	750	840	840	940	940	1000
	F-B(mm)	390	440	450	540	600	600	700	740	800
	Blanking hole (mm)	100	100	180	180	180	200	250	250	300
Throat depth	200	250	260	260	300	310	380	400	400	450
Die hole	40	50	50	60	60	60	70	70	70	80
Feight of worktable from the ground	500	550	550	600	660	680	700	750	750	800
Motor power	5.5	5.5	7.5	11	11	15	18.5	18.5	22	22



# YTD32 SERIES HYDRAULIC PRESS MACHINE

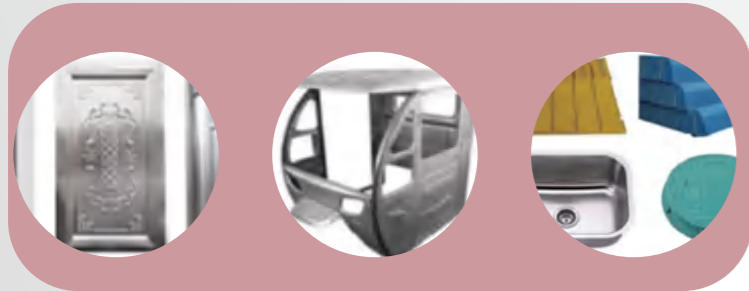

Hydraulic Cylinder



Germany Siemens main motor



Germany Bosch Rexroth integrated hydraulic valve



Workbench

## Product Description:

- It's suitable for automatic operations forming, punching, bending, straightening and multi-press assemblies to form automatic production line.
- Hydraulic control integrated system is reliable with long service life and hydraulic impact is small, reducing the leakage of pipe connections.
- Independent electrical control system, reliable, easy maintenance.
- Fully enclosed drive, easily accessible for maintenance, exposed over hanging parts, slide and bolster tables with T-slots.
- Protective fence and the safety interlock ensure the operation safety. Movable single-hand pedal switch makes it easy to operate.
- Working pressure can be customized from 5T to 500T according to client's requirements.

## Press Control (2 kinds optional)



1. Centralized button control system: With adjustment, hand semi auto operation models at operator's choice.

2. PLC controller: Man-machine interface, through the intelligent system to control the parameter adjustment of the whole machine.

# Q35Y HYDRAULIC IRONWORKER MACHINE

RAYMAX®



## Technical parameter of IRONWORK Q35Y Series

Q35Y Series industrial-grade hydraulic Iron Workers have multiple functions, which includes: Punch, Angle Shear, Flat Shear, Round/Square Bar Shear, Rec. Notch, V-Notch, Channel Shear, I-beam Shear, T-bar Shear, Press Brake, Angle Bending and Pipe Notching. Its standard configurations are: quick-change coupling nut & sleeve, squaring arm with scale, electronic back gauge, gauging table with stops, punching base table, safety guards and more.



Punching Station



Square Bar Cutting



Angle Cutting Station

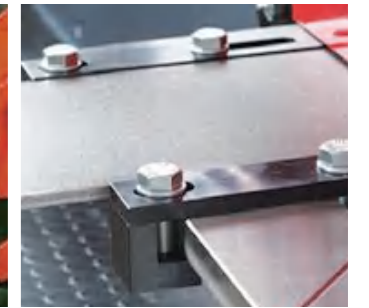

Shearing Station

## Technical Parameters:

Model	Q35Y-12	Q35Y-16	Q35Y-20	Q35Y-25	Q35Y-30	Q35Y-40	Q35Y-50
Punching Pressure(T)	35T	60T	90T	115T	145T	200T	250T
Max.cutting thickness of steel plates(mm)	12	16	20	25	30	40	50
Plate strength(N/mm <sup>2</sup> )	≤450	≤450	≤450	≤450	≤450	≤450	≤450
Angle of Shear	7°	7°	8°	8°	8°	8°	8°
A trip size(T×W)(mm)	12×160 6×300	16×250 8×400	20×330 10×480	25×330 16×600	30×335 20×600	40×335 30×600	50×300 30×750
Trips frequency(times /min)	10-18	11-20	12-20	8-18	6-16	6-16	6-12
Throat depth(mm)	115	300	355	400	600	530	600
Punch depth(mm)	12	16	20	25	28	35	40
Max.punching diameter(mm)	25	25	30	35	38	40	45
Main Motor Power(KW)	4	5.5	7.5	11	15	18.5	18.5
Overall dimensions(L×W×H) (mm)	950×550×1800	1740×810×1830	1950×900×1950	2355×960×2090	2800×1050×2450	2900×1100×2500	3200×1440×2500

# Y41 SERIES HYDRAULIC PRESS MACHINE



## PRODUCT FEATURES

With a three-beam and four-column structure, this type of press is designed economically and practically. The hydraulic system adopts an advanced cartridge inserted valve integrated system which has large flow, low pollution, easy control, and reliable performance. The independent electrical control system ensures the performance of system reliability and operability. The machine uses button centralized control, which can be operated in manual/semi-automatic model. The pressure of work and the scope of the stroke, in accordance with the provisions of demand within the scope of adjustment and the constant pressure complete and schedule two-way process. Meanwhile, there is a time delay of press forming under fixed pressure. Working pressure and stroke can be adjusted within a certain scope.

## SPECIFICATIONS

Specification		YTD37	YTD37	YTD37	YTD37	YTD37	YTD37	YTD37	YTD37	YTD37	YTD37	YTD37	YTD37	YTD37
Description		-40	-63	-100	-160	-200	-315	-400	-500	-630	-800	-1000	-1250	-1600
Rated pressure	KN	400	630	1000	1600	2000	3150	4000	5000	6300	8000	10000	12500	16000
Maximum pressure of liquid	MPa	25	25	25	25	25	25	25	25	25	25	25	25	25
Rated pressure	KN	120	190	190	400	400	630	630	1000	1000	1600	1600	1600	2000
Rated pressure	mm	450	500	600	700	700	800	800	900	900	900	900	900	900
Rated pressure	mm	150	200	200	200	250	300	300	350	350	350	350	400	400
Rated pressure	mm	750	750	880	1000	1100	1250	1250	1500	1500	1500	1500	1500	1500
Speed of slide	Descent	mm/s	160	180	120	100	100	100	100	100	80	80	80	80
	Pressing	mm/s	20-25	15-20	10-14	10-15	10-15	8-12	6-10	10-15	6-10	10-12	10-12	8-10
	Return	mm/s	120	100	120	70	70	60	55	70	60	70	70	55
Work table size		mm	500	580	720	1000	1000	1260	1240	1400	1500	1600	1600	1700
		mm	460	500	580	800	900	1120	1200	1400	1500	1600	1600	1600
Motor power	KW	5.5	7.5	7.5	11	15	22	22	2*22	2*22	2*30	2*30	2*27	2*27